

EVALUATION OF THE GUARD RAIL ENERGY ABSORBING  
TERMINAL (G-R-E-A-T) IMPACT ATTENUATOR

FINAL REPORT

BY

WILLIAM C. WALTERS  
RESEARCH AND DEVELOPMENT GEOLOGIST

Research Report No. 160

Research Project No. 79-3G(B)

Conducted by  
LOUISIANA DEPARTMENT OF TRANSPORTATION  
AND DEVELOPMENT  
Research and Development Section  
In Cooperation with  
U. S. Department of Transportation  
FEDERAL HIGHWAY ADMINISTRATION

"The contents of this report reflect the views of the author who is responsible for the facts and the accuracy of the data presented herein. The contents do not necessarily reflect the official views or policies of the State or the Federal Highway Administration. This report does not constitute a standard, specification, or regulation. The Louisiana Department of Transportation and Development does not endorse products, equipment, processes or manufacturers. Trademarks or manufacturers' names appear herein only because they are considered essential to the object of this report."

SEPTEMBER 1982

## ABSTRACT

This short report evaluates as many aspects of the Guard Rail Energy Absorbing Terminal (G-R-E-A-T), a vehicle attenuator, as possible. The system was first installed on a particular bridge in September 1979 and was evaluated for three years. No impact occurred during that interval, so an evaluation of impact worthiness could not be assessed. However, installation and its resistance to weather are evaluated.

The installation presented no problem. However, about two years after its installation, the system's energy absorbing modules had to be replaced because of moisture damage. A new design of the energy absorbing cartridge was installed. They have shown no damage thus far.

## TABLE OF CONTENTS

ABSTRACT -----	iii
LIST OF FIGURES -----	vii
IMPLEMENTATION -----	ix
INTRODUCTION -----	1
PURPOSE AND SCOPE -----	6
METHODOLOGY -----	8
RESULTS AND OBSERVATIONS -----	9
CONCLUSIONS -----	16

## LIST OF FIGURES

<u>Figure No.</u>		<u>Page No.</u>
1	Hi-Dri Cell Assembly -----	2
2	Hi-Dri Cartridge Assembly -----	3
3	G-R-E-A-T System -----	4
4	Hi-Dri Sandwich Unit -----	5
5	Hex-Foam Cartridge Assembly -----	12
6	Distant View of G-R-E-A-T System -----	14
7	Close-up View of G-R-E-A-T System -----	14
8	Hex-Foam Cartridge Assembly Installed -----	15

## IMPLEMENTATION

The Department can use this device in areas where there is insufficient space for the regular crash attenuation devices. The system has been crash tested by the manufacturer and has met all requirements thereof. Even though the G-R-E-A-T system with the retrofitted cartridges has been evaluated for only a short time, the replacement cartridges seem to be more weather resistant than those originally installed.

## INTRODUCTION

The Guard Rail Energy Absorbing Terminal (G-R-E-A-T) experimentally installed at Bayou Choupique in Louisiana is a traffic impact attenuator which is designed to attenuate crashes of heavy automobiles traveling at high speeds to average decelerations that are low. It is not unlike a standard Hi-Dro cushion unit which is placed at most gore abutments or bridge abutments in Louisiana, except that it has no water-filled cartridges (balloons) to absorb the crash. Instead, the G-R-E-A-T's absorbing feature is a cell which is a seven-inch in diameter by varying length hollow cylinder made of vermiculite concrete wrapped by wire and covered with foil and asphalt. These cells are placed between two or three pieces of plywood and the whole system is encased in a plastic-covered cardboard box. This then is one cartridge assembly (see Figures 1 and 2).

Another difference is that the fish-scale, fiberglass panels along the sides of the Hi-Dro cushions (called fender panels) are replaced by telescoping third-beam guard rails which slide over one another when impacted. These then are the major differences. For some of the other differences refer to Figures 3 and 4.

These devices fit into spaces that the larger Hi-Dro cushions won't; this is the reason for evaluation. The Louisiana Department of Transportation and Development was in the process of lengthening the bridge over Bayou Choupique in St. Mary Parish when it was discovered that the gore and abutment would be restricted and it could not accommodate a standard Hi-Dro cushion. Therefore, a Federal Highway Administration Category 2 experimental feature was initiated to install and evaluate a "G-R-E-A-T" impact attenuator at this location. This is the evaluation.

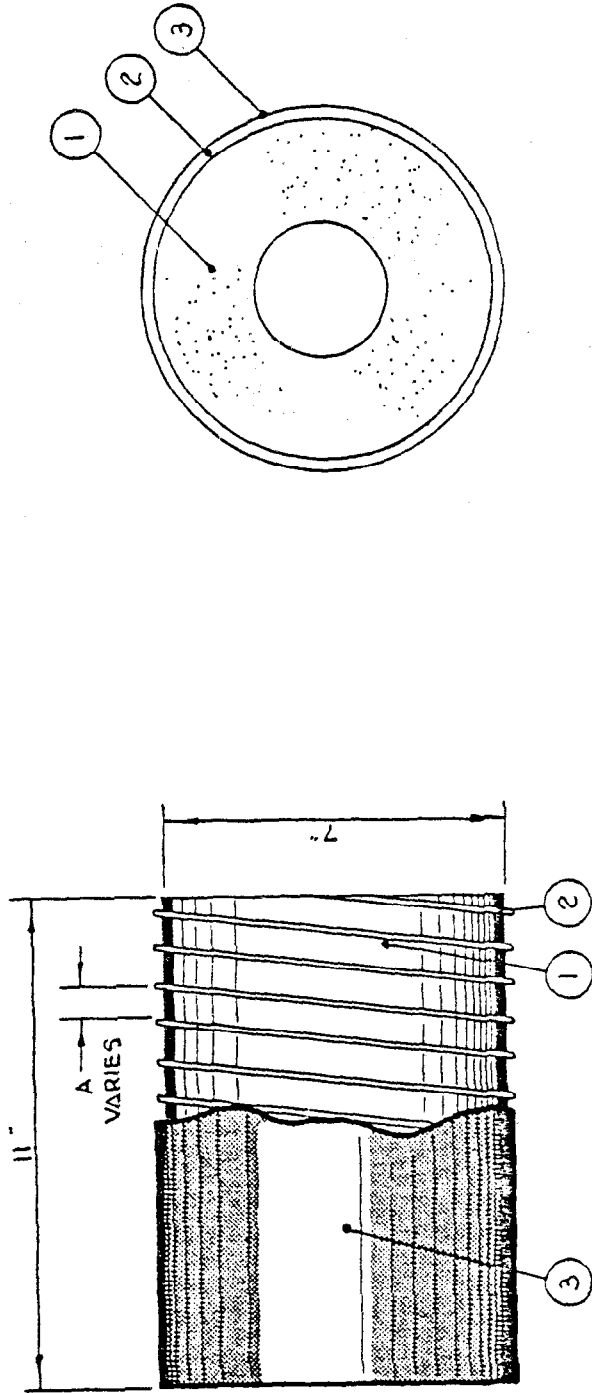

- ① VERMICULITE CELL
- ② WIRE WRAP
- ③ FOIL WITH ASPHALT COATING

Hi-Dri Cell Assembly

FIGURE 1

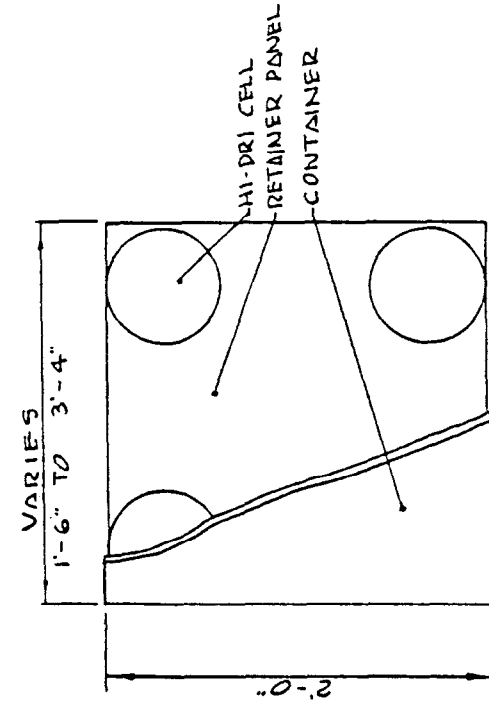
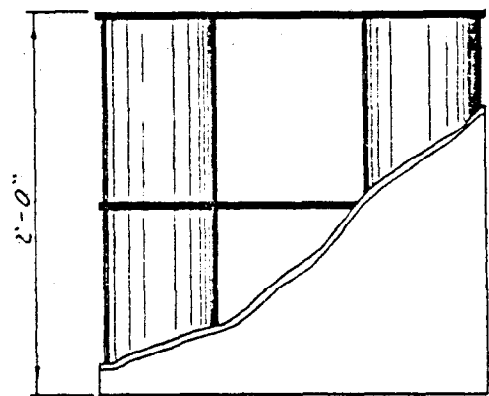
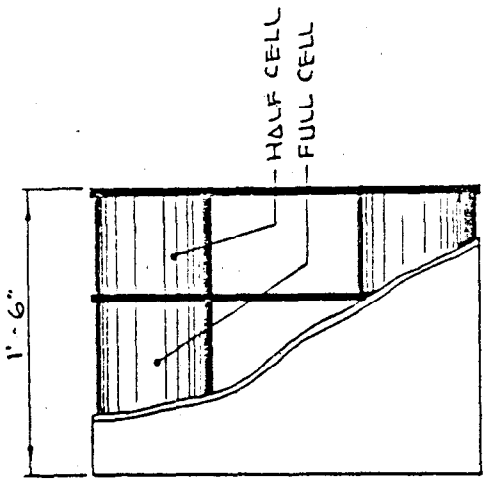

SIDE

SIDE

FRONT

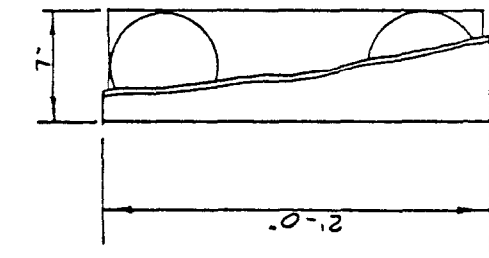
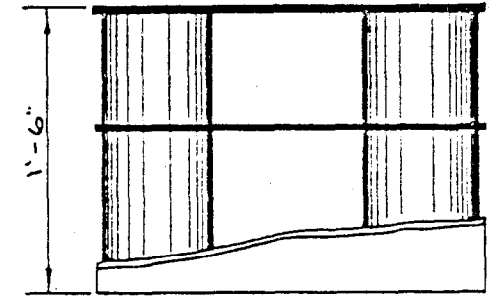
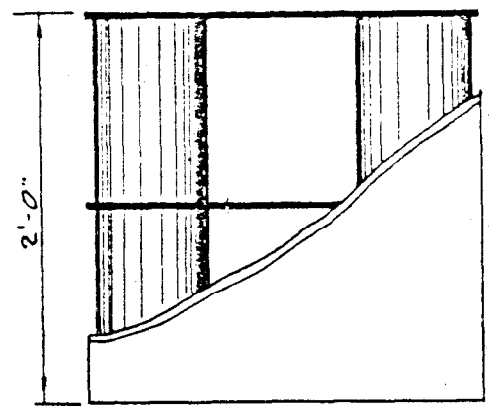

SIDE

SIDE

FRONT

NOTES:

1. CARTRIDGE SIZES ARE 7", 1'-6", 1'-10", 2'-2", 2'-6", & 3'-4" WIDTHS.
2. CARTRIDGES SHOWN ARE TYPICAL. EACH OF THE LARGER CARTRIDGES CONTAIN EITHER 8 OR 12 CELLS. THE NARROW 7" CARTRIDGE HAS 4 OR 6 CELLS.
3. CARTRIDGE DESIGNATIONS AND THEIR LOCATIONS ARE SHOWN ON THE PLAN DRAWING FOR EACH SPECIFIC UNIT.

Hi-Dri Cartridge Assembly

FIGURE 2



ITEM	DESCRIPTION
1	HI-DRI CARTRIDGE
2	DIAPHRAGM
3	FENDER PANEL - THREE BEAM
4	ANCHOR CHANNEL
5	NOSE SECTION
6	ANCHOR BOLT (CONC EXP TYPE) 1/2 IN DIA
7	SHEAR BOLTS 1/2 IN DIA (FOR THRU LAST BRT)
8	MUSHROOM BOLT ASSEMBLY

UNIT IDENTITY PLATE IS LOCATED AT TOP RIGHT, REAR OF LAST DIAPHRAGM

\* SIZES VARY PER UNIT SIZE. ORDER THESE PARTS PER INSTRUCTIONS ON INSIDE COVER.

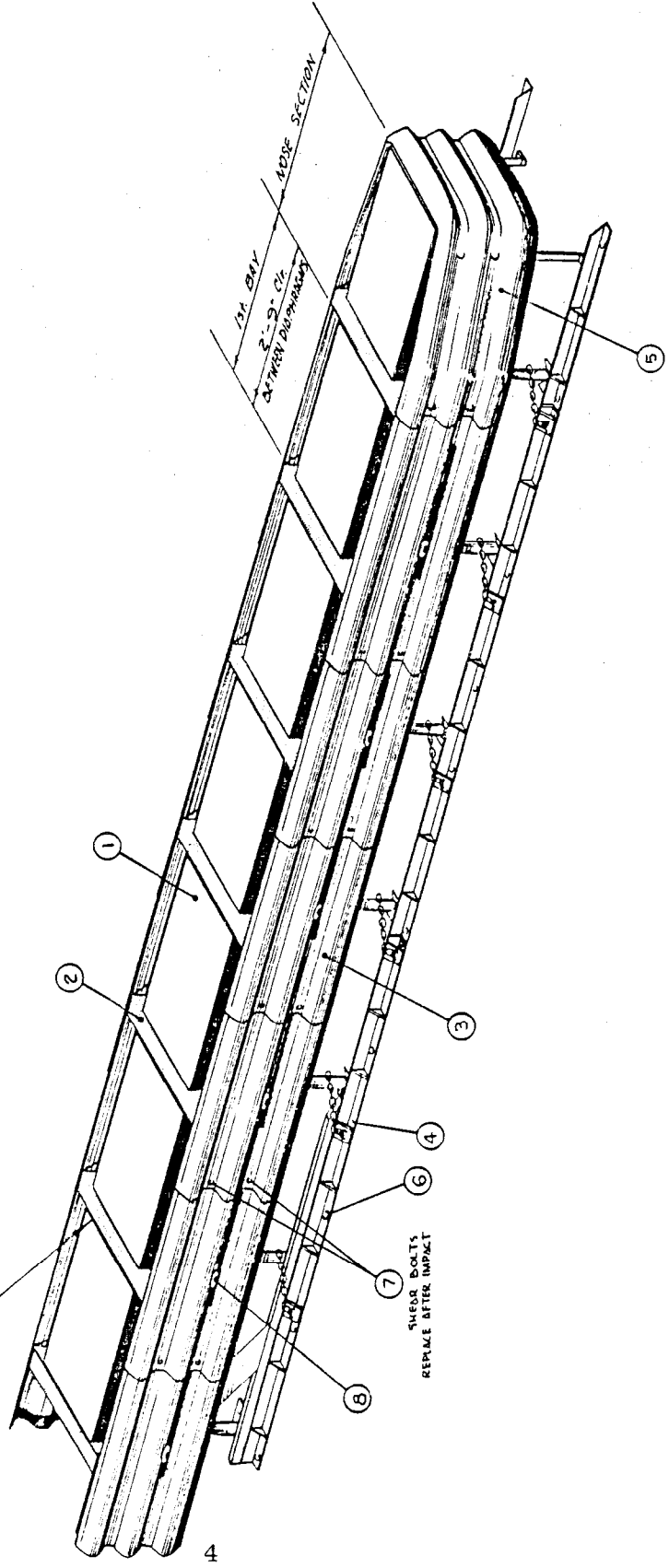

G-R-E-A-T System

FIGURE 3

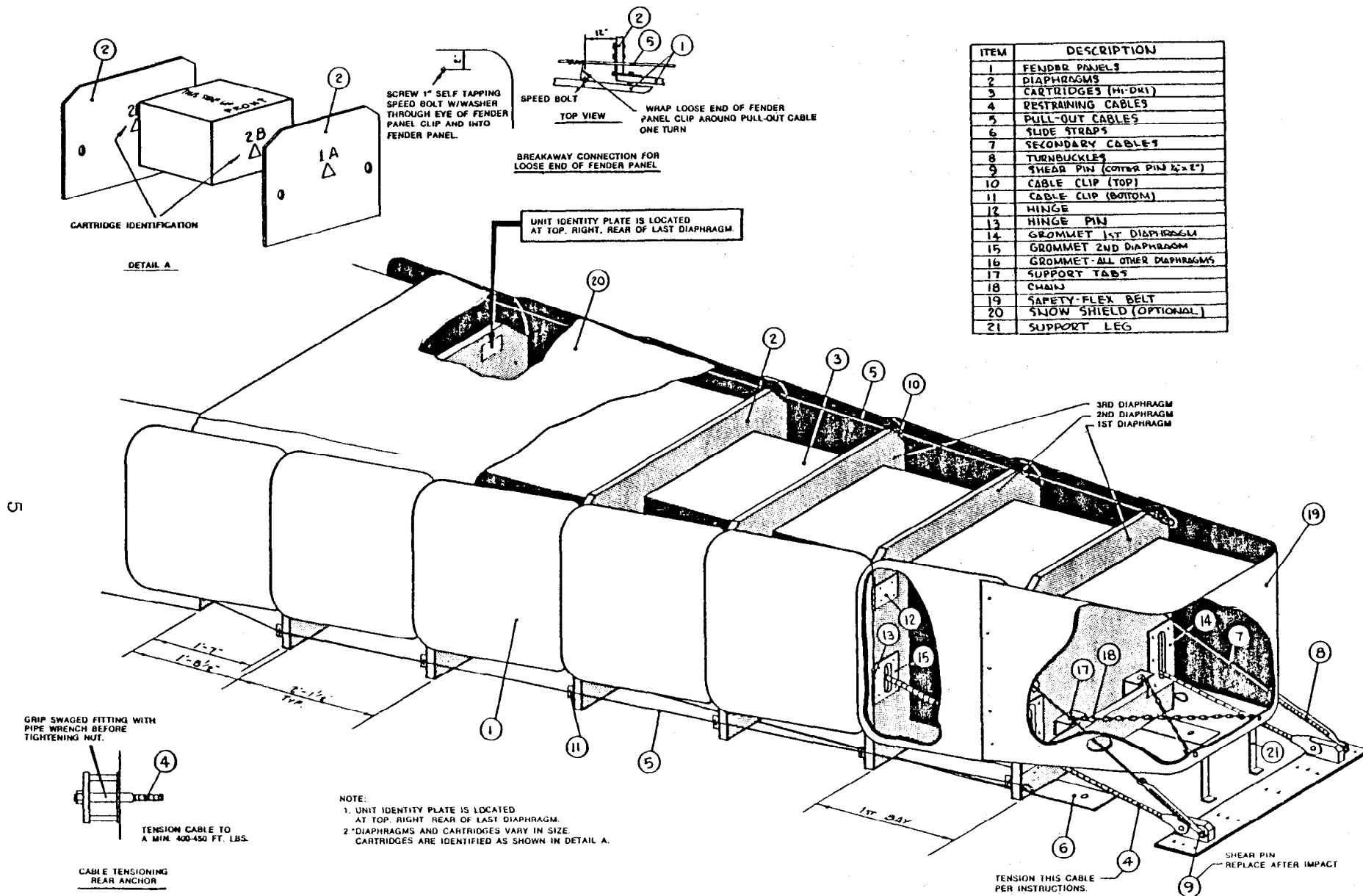

ITEM	DESCRIPTION
1	FENDER PANELS
2	DIAPHRAGMS
3	CARTRIDGES (HI-DRI)
4	RESTRAINING CABLES
5	PULL-OUT CABLES
6	SLIDE STRAPS
7	SECONDARY CABLES
8	TURNBUCKLES
9	SHEAR PIN (COTTER PIN 1/4"x2")
10	CABLE CLIP (TOP)
11	CABLE CLIP (BOTTOM)
12	HINGE
13	HINGE PIN
14	GROMMET 1ST DIAPHRAGM
15	GROMMET 2ND DIAPHRAGM
16	GROMMET-ALL OTHER DIAPHRAGMS
17	SUPPORT TABS
18	CHAIN
19	SAFETY-FLEX BELT
20	SNOW SHIELD (OPTIONAL)
21	SUPPORT LEG

NOTE:  
 1. UNIT IDENTITY PLATE IS LOCATED AT TOP, RIGHT REAR OF LAST DIAPHRAGM.  
 2. DIAPHRAGMS AND CARTRIDGES VARY IN SIZE. CARTRIDGES ARE IDENTIFIED AS SHOWN IN DETAIL A.

Hi-Dri Sandwich Unit

FIGURE 4

## PURPOSE AND SCOPE

The purpose of this evaluation was implied in the introduction. Specifically, the Department wanted to install an impact device at the narrow gore created by the lengthening of the Bayou Choupique bridge (S.P. 424-05-54, F.A.P. F-11-05[002]) in St. Mary Parish. The G-R-E-A-T system was chosen because it was suitable for narrow-site hazards where other systems were not. However, the Department wanted a full evaluation of this system in order to decide whether it would be suitable for other narrow-site hazards.

The evaluation envisioned three parts:

1. Evaluation of installation.
2. Evaluation of a hit(s), if any.
3. Evaluation of long-term repairs without hits.

The last two parts are mutually exclusive; i.e., if the device were hit sometime within the three-year evaluation, then a long-term evaluation of repairs could not be reported because of the replacement of parts that would be necessary. On the other hand, if a long-term evaluation were able to be made, then the G-R-E-A-T's crash worthiness could not be appraised. Nevertheless, the scope was as follows:

1. Evaluation of the Installation.

This phase required nothing more than the observation of the installation and report of any problem that arose such as: whether the procedure was difficult, how much and what type of equipment was involved, whether the procedure was subject to error, and the like. If there were no problems, this was to be documented as well.

2. Evaluation of hit(s).

If the system were hit within the evaluation period, the information to have been reported was:

- a. Type of hit (head-on or redirection).
- b. Type of vehicle (model).
- c. Speed of vehicle.
- d. Damage to both vehicle and G-R-E-A-T.
- e. Injury (injuries).
- f. Trouble to and cost of repair to attenuator.
- g. Cost to repair vehicle (if information is available).

3. Evaluation of long-term repairs.

This evaluation was only the observation of whether the system was climate worthy, i.e., could the unit stand up to the heat, sun, rain, cold, and traffic spray and dirt without coming apart.

## METHODOLOGY

At the inception of this project the researchers were at the site to observe the installation of the device. Then the resident project engineer was asked to notify the investigators of any hits as soon as possible after the impact. Until such time as an impact occurred the researcher paid periodic visits to the site to inspect the system, usually once a quarter.

## RESULTS AND OBSERVATIONS

The Guard Rail Energy Absorbing Terminal (G-R-E-A-T) was installed on the Bayou Choupique Bridge (Lengthening) Project in St. Mary Parish on September 18, 1979, under the contract for the bridge lengthening. The bid price for the G-R-E-A-T system and its installation was \$16,000.

### The Installation

The contractor arrived at 9:30 a.m. with the system having been partially assembled in their shop. They had put together the eight-bay unit in two parts: the three-beam guard rail fender (side) panels, the diaphragms, and support legs were assembled into two four-bay units and loaded on a flatbed truck together with the Hi-Dri cartridges.

The equipment needed to install the G-R-E-A-T was a hydraulic winch preferably mounted on the truck used to carry the bulk items, a gasoline generator capable of delivering 110 VAC, a roto hammer for drilling holes in concrete, 1/4" electric drill, sledge hammer, and assorted small tools including a pipe wrench.

In this case the prime contractor poured the portland cement concrete apron upon which the device was mounted (some sort of apron is a necessity) and supplied the bridge parapet suitable to act as a backup plate for the G-R-E-A-T, i.e., the front of the parapet was formed with a flat face instead of the usual rounded one.

The ten-step procedure was relatively easy, the hardest part being anchoring the guide rails (proper name--Chain Rails) to the concrete apron. The entire operation was completed in four hours. The reader is reminded that there was no site preparation necessary and that the crew knew the procedure. Preassembling the device before coming to the field was expeditious to the matter.

Observation of the device continued for three years after its erection. There were no collisions during this period of observation. Therefore, this report can comment only on the G-R-E-A-T's weather worthiness.

The system suffered no weather damage for the first nine months. It was in June 1980 that the investigators first noticed a tear in the top of one waterproofing, plastic covering that surrounded the cardboard container of the Hi-Dri cells (Figure 3). The plastic actually had a sunburned appearance. On subsequent inspections, all cartridges exhibited tears and water penetration became excessive. By September 1981, approximately two years after installation, water penetration had deteriorated the cardboard cartridges so as to render them unsuitable to sustaining a collision. The following was a description submitted June 30, 1981.

On June 16, 1981, the principal investigator traveled to the site of installation in order to inspect the system. While the G-R-E-A-T showed no signs of being hit, it did show considerable weather damage. All plastic covers on the top of the cartridges are now gone. The cardboard boxes which are the cartridges are showing water damage. All have holes in their tops, and cartridge No. 10 is also deteriorated at the bottom so that one can see the ground looking through it. The system is still structurally sound and looks as though it will sustain a hit at present. Nevertheless, the investigator has recommended that all cartridges be replaced.

Late August or early September some of the Hi-Dri cells had slipped to the bottom of their cartridges. June 22, 1981, it was recommended that all cartridges be replaced.

#### Replacement

Prior to the recommendation letter (June 18, 1981), the Department received notification that the manufacturer had crash tested the G-R-E-A-T with a new design for the Hi-Dri cartridge. It is called

the Hex-Foam cartridge. A portion of a paper by the manufacturer is quoted below.

The goal of this project was to develop a new G-R-E-A-T cartridge which weighed less, had improved crush characteristics, provided good environmental packaging, and had a low replacement cost....

After numerous experiments to determine the crush characteristics of different materials, it was found that a paper honeycomb matrix stabilized with foam provided excellent crush characteristics. This material was formed by placing 1" thick layers of paper honeycomb on top of each other, in a cross-ply orientation, and foaming through the stack with polyurethane foam. This combination of paper honeycomb and foam was called Hex-Foam....

The new Hex-Foam cartridge consists of the Hex-Foam material, a polyethylene bag for environmental protection, a burlap bag to contain the debris after an impact, and an outer semi-rigid container made of cross linked polyethylene. The outer container is made from the same material that has proven its weathering capability in both the G-R-E-A-T nose wrap and the Energite lid.\*

Figure 5 is a drawing of the Hex-Foam cartridge.

Also two other modifications were added to the G-R-E-A-T system but were mentioned only in the conclusions of a paper by Energy Absorption Systems. These were the brackets for holding the Hex-Foam cartridges in place and a restraining cable that runs for the full length of the system. The cable consists of a wire rope anchored to the concrete apron by two "cable anchor assemblies." The rope is held to the two front bays of the G-R-E-A-T by two brackets bolted to the diaphragms. The entire retrofitting kit was purchased for \$3,539.20.

---

\*Energy Absorption Systems, Inc. "Crash Test Results of Hex-Foam Cartridges in G-R-E-A-T Attenuators," West Sacramento, California, March 1981.



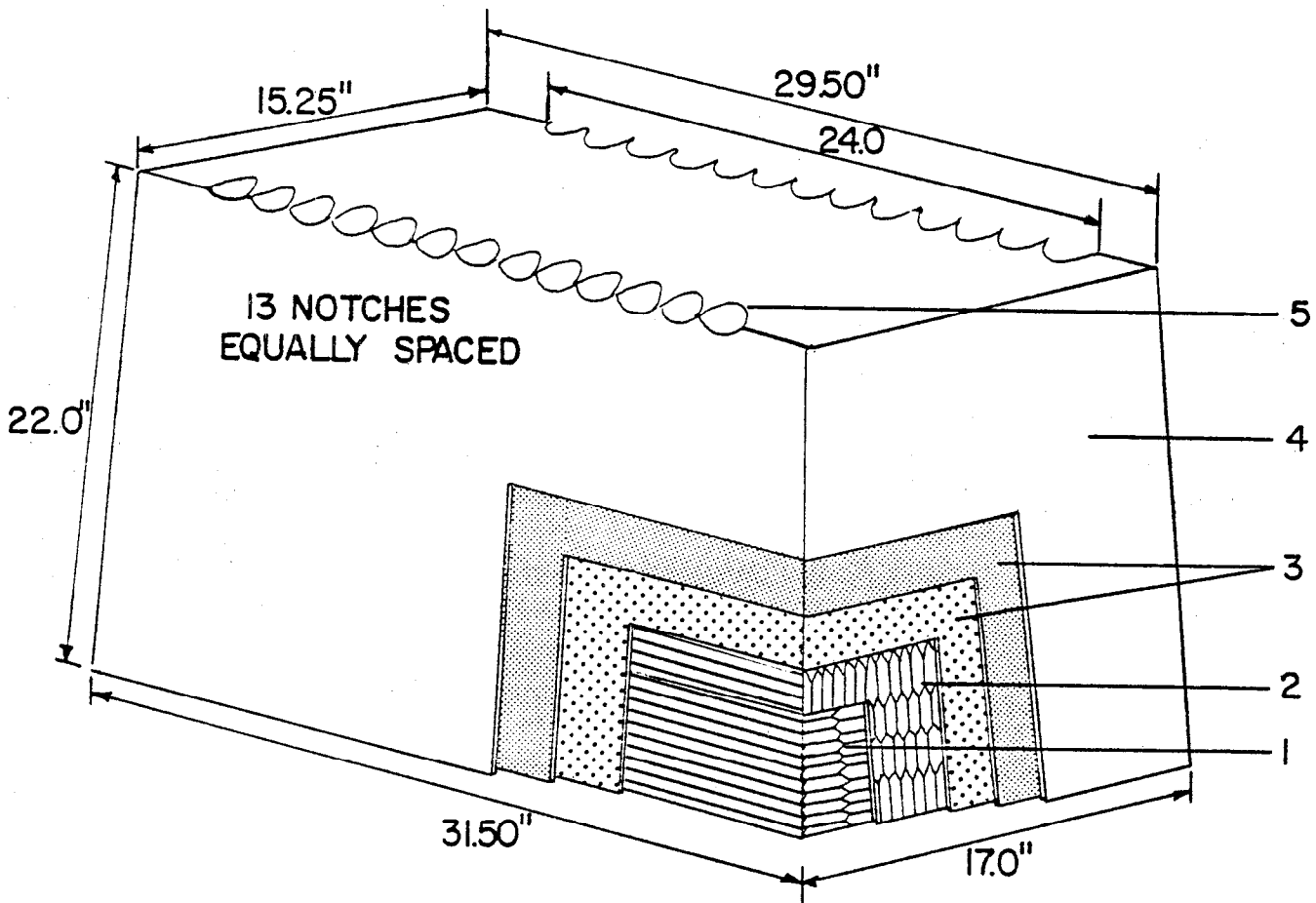

- 1 - CARDBOARD HONEYCOMB LAYERS IN TWO HEXAGON SIZES WHICH ALTERNATE THROUGHOUT THE CELL IN A CROSS-HATCH ARRANGEMENT
- 2 - POLYURETHANE FOAM FILL
- 3 - BURLAP AND PLASTIC LININGS
- 4 - POLYETHYLENE CONTAINER
- 5 - ACCORDION PLEATS TO ALLOW COMPRESSION

*Hex-Foam Cartridge Assembly*

FIGURE 5

On November 30, 1981, a district maintenance crew replaced the Hi-Dri with the new Hex-Foam cartridges, installed the cartridges' support brackets, and installed the restraining cable in one day. The maintenance crew stated that the retrofitting presented no problem; that becoming familiar with the system was the most confusing part of the whole operation. A breakdown of the crew's charges is as follows:

Labor	\$ 219.58
Benefits	98.43
Subsistence	40.00
Equipment Rental	<u>133.13</u>
Total	\$ 491.08
Replacement Kit	\$3,539.20
Grand Total	\$4,030.28

Since the installation of the new system, there has been no damage by vehicle or by the weather to the attenuator.

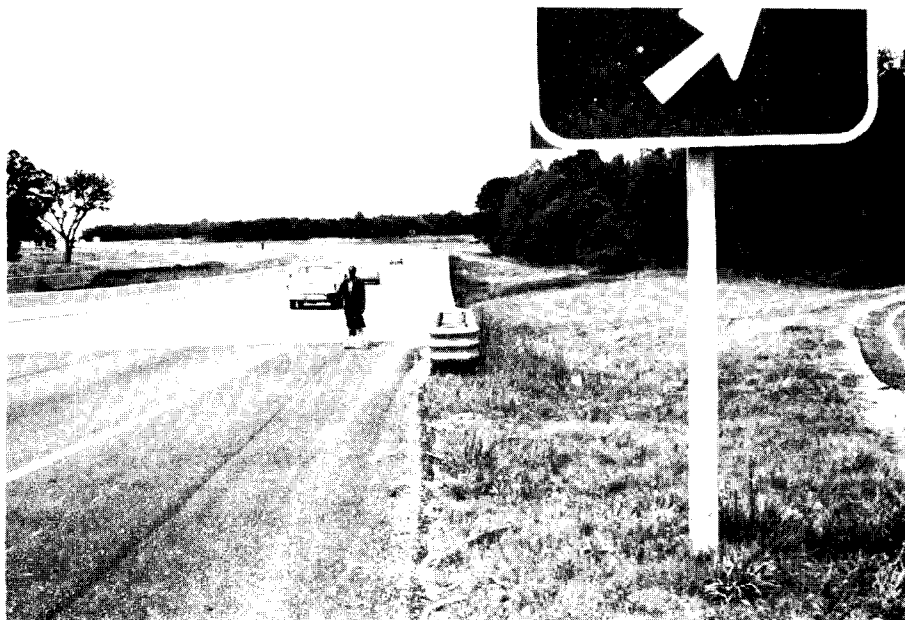

*Distant View of G-R-E-A-T System*

*FIGURE 6*



*Close-up View of G-R-E-A-T System*

*FIGURE 7*

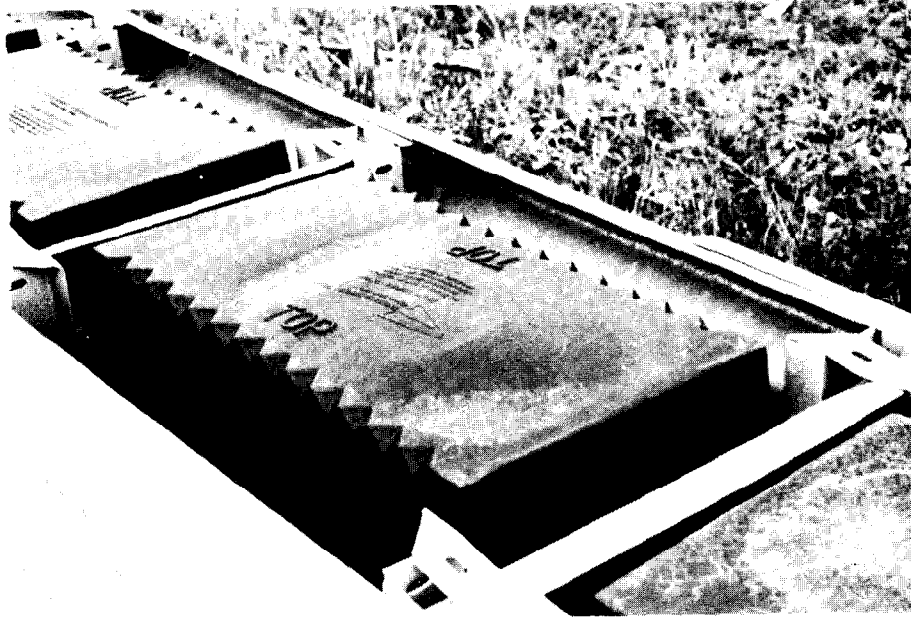

*Hex-Foam Cartridge Assembly Installed*

*FIGURE 8*

## CONCLUSIONS

1. Since no impact has occurred, specific conclusions cannot be made about the system's crash worthiness.
2. The system as it was installed was not weatherproof as claimed by the manufacturer.
3. The replacement of the cartridges that was necessary two years after installation was accomplished with an improved "Hex-Foam" design. This type of cartridge seems to be more weather resistant than the original.
4. Both the original installation by the manufacturer's representative and the subsequent repairs, including the installation of the restraining cable and the support brackets by maintenance personnel, presented little problem.